

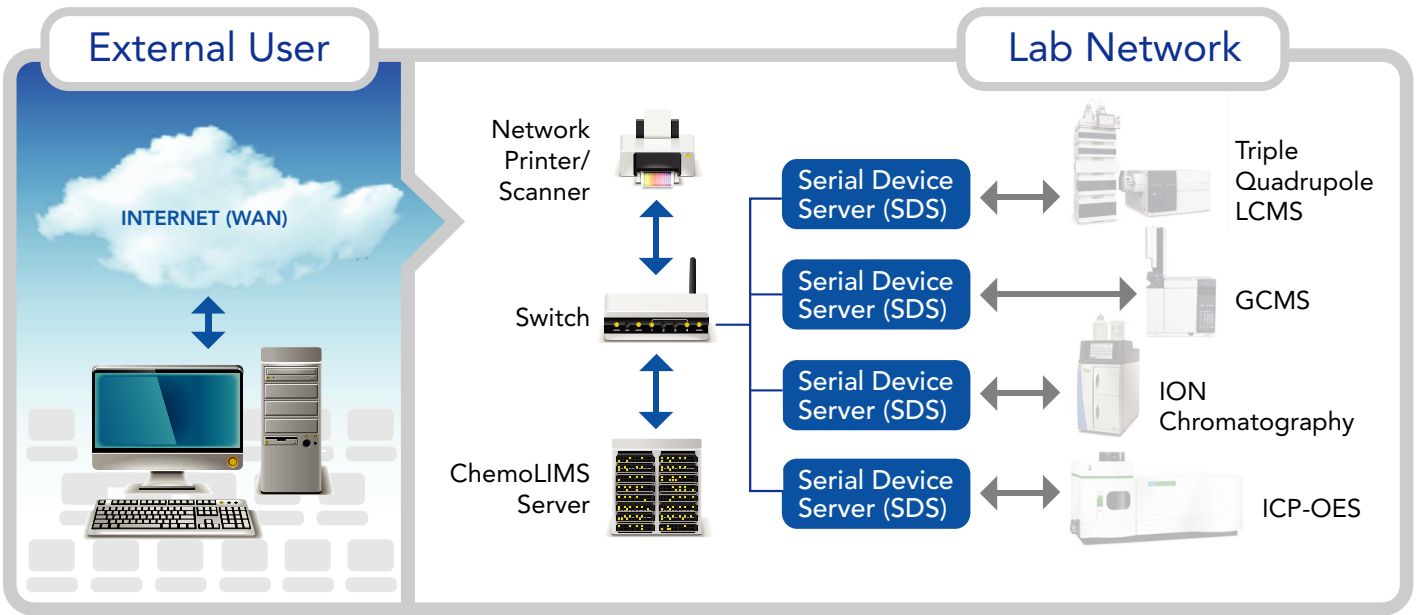

Laboratory Information Management Solutions

How ChemoLIMS NX works?



QC and QA Workflow Diagram

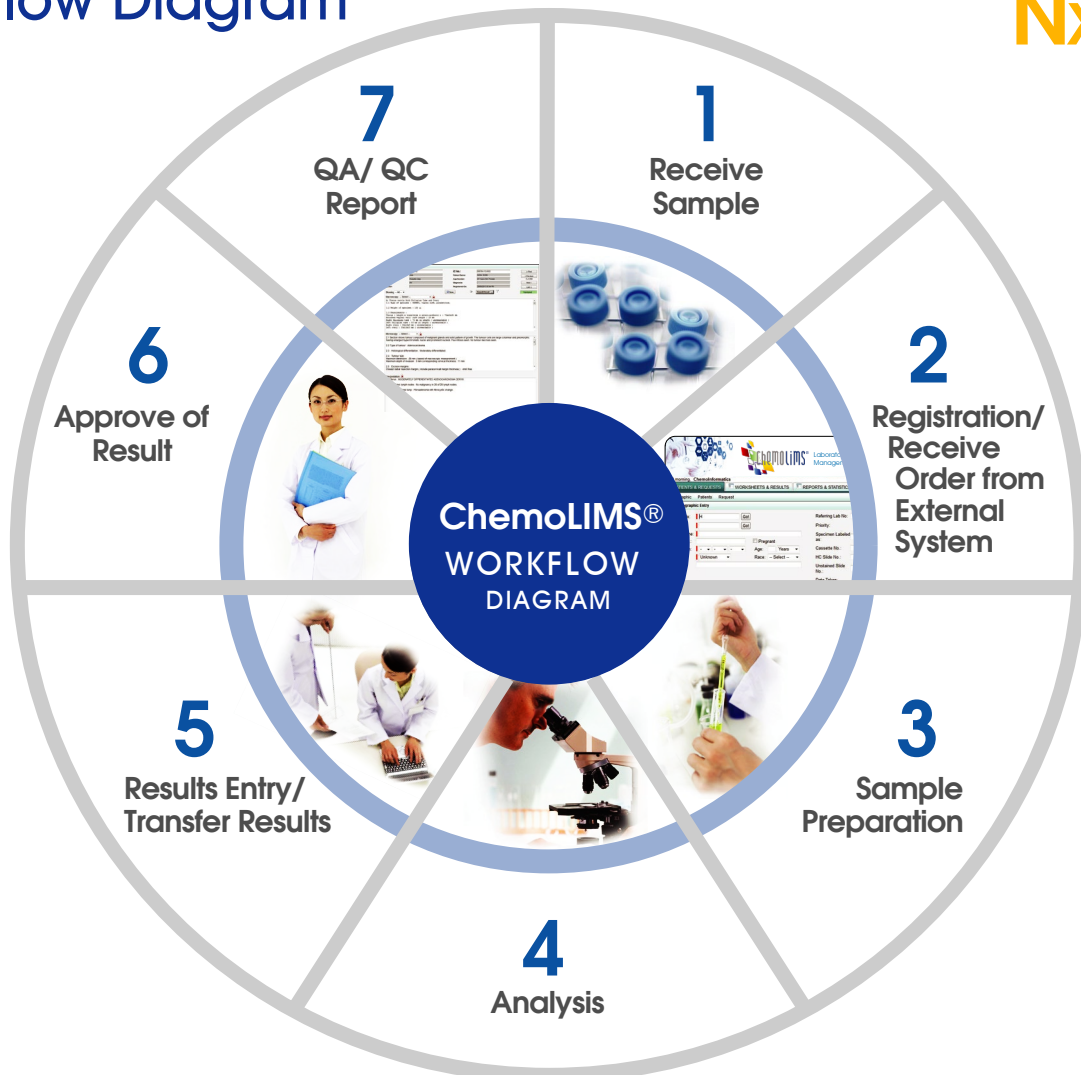

INTRODUCTION

ChemoLIMS® provides all the basic functionality required in a LIMS including sample/work registration, test allocation, sample receipt, sample preparation, result entry, result validation, sample approval and reporting. The implementation of **ChemoLIMS®** in a laboratory will eliminate transcription and calculations errors that are inherent in manual data management.

ChemoLIMS® successful implementation will improve one's Return on Investment (ROI), profitability, quality of work and also importantly user happiness. **ChemoLIMS®** establishes a seamless integration with any scientific or analytical equipment for real-time sample data collection, archival, processing and remote access, subject to equipment capability.

THESE INCLUDE:

- Easy retrieval and viewing of raw data originating from different equipment by lab scientists.
- Centrally stored raw data is available from location to lab scientists in real-time.
- Easy management of system, data, connectors equipments by system administrators.

ADVANCED FEATURES

- Seamless integration with SAP for lots – auto login and result posting.
- Integration with various types of instruments including seamless integration with CDS (Empower 3).
- On-line entry of the observations in tablets and terminals.

FEATURES

- End - to - End Lab Management Solution
- Comprehensive functionality to address all common lab practices, see it to believe it.
- Shorter Learning Curve with OOPS model
- Electronic Worksheets and Paperless Lab
- Configurable enforcement of GLP/FDA norms.
- Easy to Master configurable workflows.
- Semi-automated system with control worksheet Print
- 3 tiers of security
 - Database
 - Application
 - Browser
- Reports to address all needs of Lab Management.
- Instrument Connectivity and Data Capturing



Software Application User Interface



Login/ Security

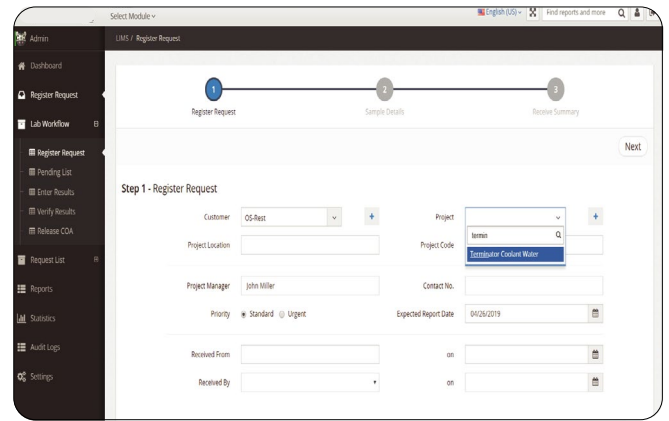

Register Request

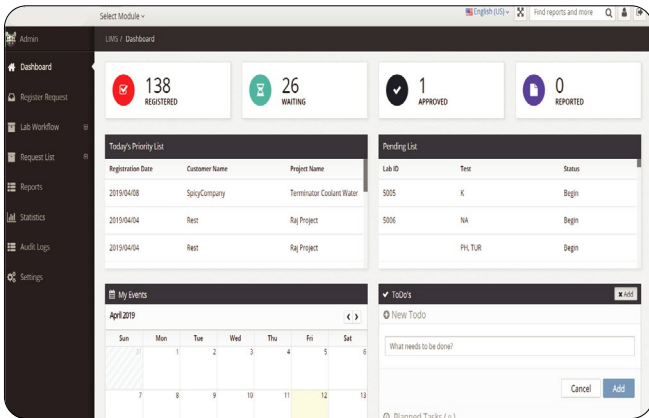

Dashboard

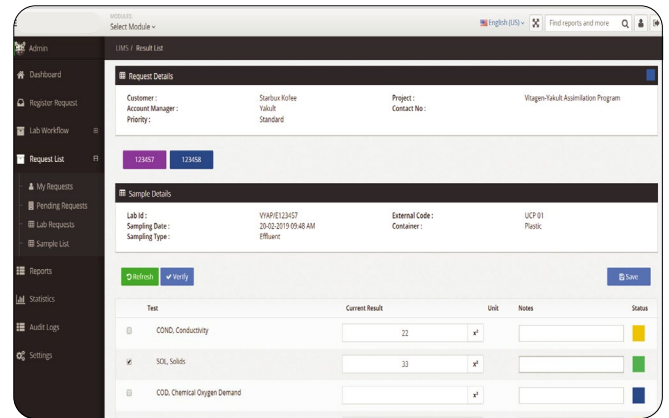

Result Entry

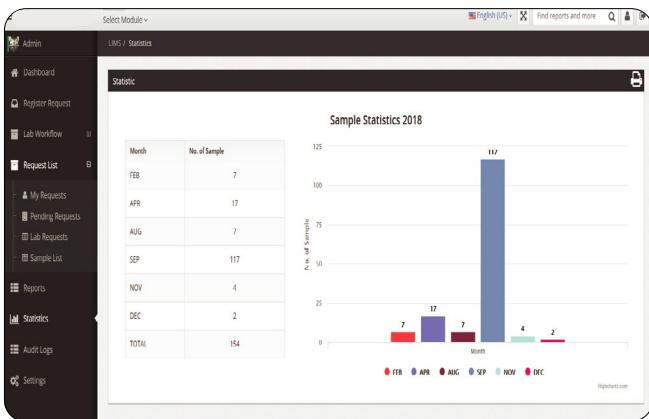

Statistic Report

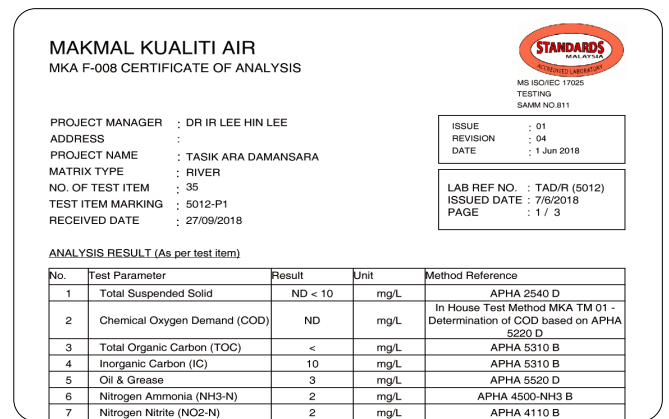

COA Report

Modules

Workflow

- With Specification
- Without Specification
- Out Source Sample
- Out of Specification

Registration

- Through Scheduler
- Through SAP/ERP
- In-house Sample
- Sample - Project Info

Sample Assignment

- Sample Type Wise (RM, IP, FP, PM)
- Test Category Wise (Chemical, Instrument, Micro)
- Test Wise (pH, LOD, Assay)

Add On

- Inventory
- Maintenance
- Docs

Sales Enquiry

ypchai@chemopharm.com.my
enquiry@chemopharm.com

+6012 335 1659
+603 7872 6000 (Hotline)



Chemopharm Sdn Bhd
20, Jalan SS2/66, 47300 Petaling Jaya
Selangor Darul Ehsan

Manufacturing | Chemoinformatics Sdn. Bhd. (71912-V)
No.20, Jalan SS2/66, 47300 Petaling Jaya, Selangor. Email: info@chemoinformatics.com

www.chemopharm.com